

SJ News

Christmas Service Schedule

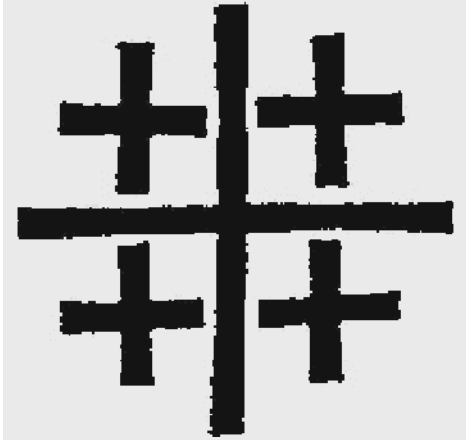

Wednesday, December 24 Christmas Eve

- 5:00 PM** Christmas Pageant & Holy Eucharist
- 10:30 PM** Music Prelude with Festal Noel Settings
- 11:00 PM** Choral Eucharist with Sermon

Thursday, December 25 Christmas Day

- 10:00 AM** Holy Eucharist with Carols

Sunday, December 28 First Sunday after Christmas

- 8:00 AM** Holy Eucharist, Rite I
- 9:30 AM** Holy Eucharist, Rite II & Sacrament of Healing

Inside this issue

Treasurer's Report	2
From the Assistant Rector.....	3
SJ Center for Children	4-5
Music & Liturgy	6
Outreach	7
Around the Parish	8-10
Women of St. James's.....	11
December Calendar	insert

Highlights in December

- First Friday Family Night, Dec 5 from 5:30 to 7pm
- Christmas Tree & Wreath Sale, Dec 5 through Dec 14
- Advent Lessons & Carols, Dec 7 beginning at 5pm
- Christmas Pageant Rehearsals, Sundays Dec 7, 14, and 21
- WOSJ Holiday Tea, Dec 13 from 2 to 4pm in the parish hall

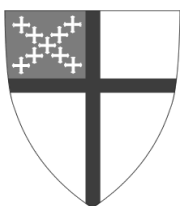

To Learn, Live and Teach the Values
of the Gospel of Jesus Christ

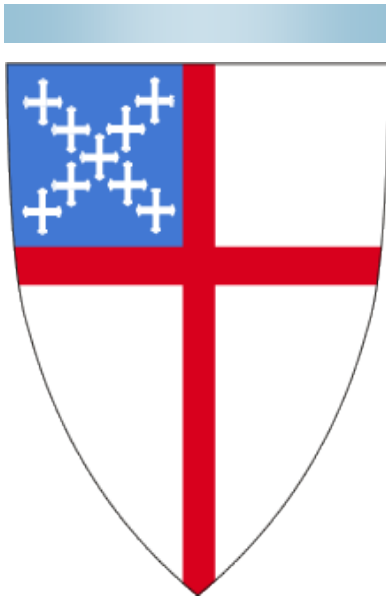

Vestry Corner

Treasurer's Report—October 2014

Current Position: During the month of October, the church saw an improvement in its overall financial position. However, as noted in the box below, the results continue to show an overall negative variance to budget. The \$2,199 negative variance at the end of October was \$6,251 at the end of September. The reasons for the shortfall are consistent with what has been reported in most months this year – pledges that trail expected levels (currently \$11,200 below budget)

balanced by expenses that are less than budget. Total income improved from \$18,600 below budget to \$12,734 below budget during the month. Expenses experienced a slight deterioration during the month but still remain more than \$10,000 less than budget. During the final two months of the year, we hope to see pledge payments increase and fall more in line with budget while we continue to monitor expenses.

“The Stewardship Campaign for 2015 is underway! If you would like to pledge and did not receive a pledge card, just phone the parish office.”

Who We Are - Some excerpts from this year's volume #3

St. James's drew Liz and me with the inclusiveness in its religious teaching. But what keeps us coming back (almost) every week is the community.

St. James's provides a community where I feel like an equally valued member among people my age and with those my parents' and grandparents' ages.

The unconditional welcoming our family felt upon coming to St. James's is what keeps us coming back and trying to pass that same experience on to others.

Income & Expense Summary:

Category	YTD Actual	YTD Budget	YTD Variance	Total Annual Budget
Income (+)	\$608,148	620,882	12,734 Below plan	764,300
Expense (-)	621,369	631,904	10,535 Below plan	764,300
<i>Net</i>	(13,221)	(11,022)	2,199 Negative variance to budget	0

Income: Year-to-date (YTD) actual income is \$12,734 below budget (or 2.1% worse than budget). As of the end of September, this figure was \$18,590 less than budget (3.4% of budget).

Expense: YTD expenses remain more than \$10,000 below budget. As of the end of October, expenses were \$10,535 below budget; this difference represents 1.7% of the budgeted amount. Expenses were \$12,338 (or 2.2%) below budget at the end of September.

From the Assistant Rector

HAVE you heard of an “electronic leash?” I’m not talking about those collars that shock dogs when they bark or leave the front lawn; I am talking about the mobile phone, the tablet, the laptop, or whatever. If not used very carefully, these useful tools—modern technological marvels—can become electronic leashes.

In two of my favorite films, *Hook* and *The Devil Wears Prada*, the workaholic main characters, full of stress and anxiety finally say “no” to their electronic leashes and throw their mobile phones out the window, in the snow, or in a fountain; apparently they weren’t aware of the “off” button. Nonetheless, they triumphantly end their workaholicism and cut their electronic leashes, as they find an enlightened way of living in an otherwise chaotic world.

A few years ago, I decided to commit to turning off my phone from sunset on Fridays to sunset on Saturdays. One Saturday night I turned on my phone to 59 unread messages, or, 59 reasons I needed to not check my phone the day before. And several months ago, Antonio and I were so sick and tired of the addictive habit we had developed of waking up to grasp for our iPhones on the nightstands, that we decided to leave all such devices downstairs, plugged into slumbers of their own.

They recharge, and so do we; the beep beep that follows plugging in separates rest and work. much the same way the traditional Sabbath ritual of havdalah marks the separation of rest and work with candles.

There is an extensive history of using candles to signify the separation of rest and work—to make a distinction between peace and chaos. “The sages explain the origins of the havdalah candle with a story: Adam (of the whole Adam and Eve thing) was frightened at the end of the first Sabbath, and God gave him the flickering havdalah candle as a promise that Sabbath would return” (Winter, 112). Adam was then able to live those other six days with hope for the seventh.

I think the 80’s music group “*Loverboy*” called this “working for the weekend.”

In our own tradition we use candles to signify moments of worship, and during Advent we use them to signify the light of Christ coming into our world.

Whoever conjured up the idea of Advent, a season of expectant hope, was either incredibly wise or had an especially sick sense of humor; it seems cruel to give us a season in which we are to expect, wait, hope, and pray in joy, when the world tells us to shop, stress, plan, and buy and get on your phone and check your messages: **YOU’RE GOING TO MISS SOMETHING!!!** Perhaps there is something to this candle lighting tradition that can help us during Advent to prepare for Christmas without being consumed by the chaos it seems to bring along.

Candlelight, in a very practical way, helps us to see; but when our stress and anxiety act as blinders that keep us from noticing the needs of others and ourselves, a ritual of candle lighting can lighten the world around us to help us see where there is need. If something as simple as this electronic leash has the ability to keep us preoccupied in a chaotic inbox, then something as simple as this candle might have the ability to help us recognize where God is bursting into our world.

While our culture makes true Sabbath near impossible, Advent gives us the opportunity to really understand our need for moments of havdalah—moments of separation.

We can turn off our phones for 24 hours every week. We can use candles to make peaceful moments in our homes. If you’re so inspired, make your own Advent wreath, light the first candle on Sunday night, say a prayer, and witness the amazing difference that even the flickering flame of candlelight can make.

If we take advantage of this opportunity of Advent, we may just catch a glimpse of God bursting through the chaos.

In Christ,

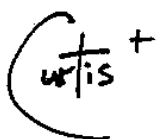

CnC Schedule

Sunday, December 21
CnC Session VI at 5pm

Sunday, January 4
CnC Session VII at 5pm
with Mentors and
Dinner in the dining
room.

Sunday, January 11
CnC Session VIII at 11am

Sunday, February 1
Session IX at 5pm

Youth Group

Second Sundays

December 14

Dinner at 5:30pm
Activity at 6:30pm
Prayer at 7:20pm
Depart at 7:30pm

Do your homework early
and invite a friend!



Bring a Friend to Church 3

St. James's Center for Children

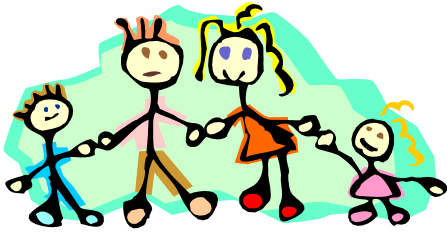

Nurturing your children's spiritual life from birth through high school

Christmas Pageant Rehearsals

Sunday, December 7

Sunday, December 14

Dress Rehearsal!

Sunday, December 21

All children and families involved in this year's Christmas Pageant must attend the rehearsals.

There will be no Christian Education on these Sundays.

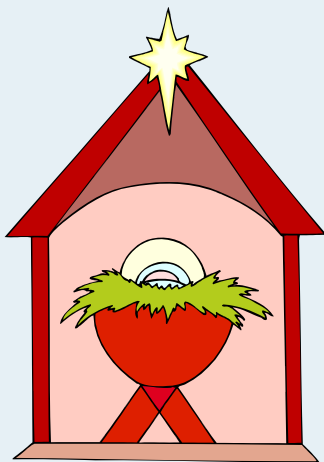

4 Bring a Friend to Church

HERE at St. James's, we began a ministry last winter called, Rhythms of Grace—a liturgical offering designed for children with special needs. We have had Rhythms of Grace now several times and I have to say, it has become one of my favorite church events each month.

The Rhythms of Grace liturgical experience presents Bible stories in an interactive way that uses music and movement, story cards, and tactile activities to develop communication skills. Most importantly, it gives families the opportunity to worship without worrying about verbal disruptions or distracting movements or gestures.

In November, we concentrated on All Saints for the Rhythms of Grace service. We had several activities, decorating small wood crosses with beads, drawing self-portraits and playing ring toss, to name a few. We also put little halos over primitive drawings of ourselves to symbolize that we are all saints and members of God's family.

In the Rhythms of Grace curriculum, it said that the ring toss game would help cement the idea of halos, and that we are all saints. I have to say, I was doubtful about that.

Then, it happened. The children started taking the rings for the ring toss and putting them over their heads like halos. I was pleasantly surprised.

It occurred to me, especially this month that Rhythms of Grace as a liturgical experience would be good for all children, not just those with special needs. Having an opportunity to hear Bible stories and explore them through crafts and activities AND having the opportunity to experience communion

on a more intimate level is something that every child should experience—or for that matter every person in the parish.

So, that being said, I am extending an invitation to you all. **On Sunday, December 14 at 4:00** we will have a special Nativity Rhythms of Grace. If you have children, bring them. If you are a child at heart, come. I promise it will not disappoint.

As you probably know, the Christmas pageant rehearsals take place after the 9:30 service on December 7, 14 and 21. If you are able to help with costumes, organizing children or as a loft manager or side door manager, please let me know. This is a big undertaking with about 70 children involved so if you can help, please do.

As always, keep the children of this parish in your prayers. This month, pray for me too, I am going to need it!

Your Sister in Christ,

Priscilla



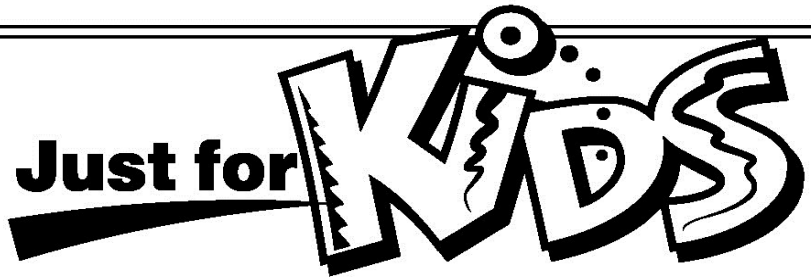
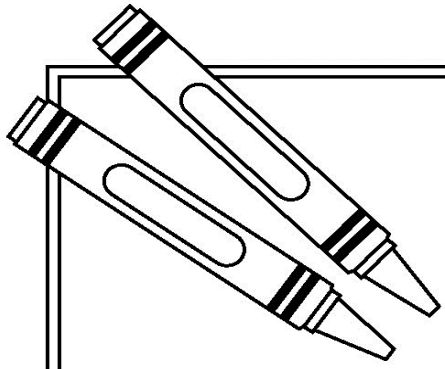

The Birth of Jesus Foretold

The prophet Isaiah foretold the birth of Jesus Christ. Isaiah knew that Jesus would be called a peacemaker, but that He would also be called by other names.

Use the code to find out what Isaiah said Jesus would be called.

CODE:

A	B	C	D	E	F	G	H	I	J	K	L	M	N	O	P	Q	R	S	T	U	V	W	X	Y	Z
Z	Y	X	W	V	U	T	S	R	Q	P	O	N	M	L	K	J	I	H	G	F	E	D	C	B	A

Z M W S V D R O O Y V

X Z O O V W D L M W V I U F O

X L F M H V O L I , N R T S G B

T L W , V E V I O Z H G R M T

U Z G S V I , K I R M X V

L U K V Z X V .

Isaiah 9:6, NIV

Answer: And He will be called Wonderful Counselor, Mighty God, Everlasting Father, Prince of Peace.

From the Organist & Choirmaster

THE seasons of Advent and Christmas will feature many contemporary choral works, and I would like to take this opportunity to introduce two of them here. The first piece will be heard on Sunday, December 14 during the Offertory. Though this particular service is held on the third Sunday of Advent, it is also the two year anniversary of the tragedy in Newtown, Connecticut. I therefore thought it was fitting to have the choir sing James MacMillan's *A Child's Prayer*, a piece written shortly after the 1996 shooting at Dunblane Primary School, Scotland, where 16 children and one teacher lost their lives. MacMillan is Scotland's leading composer of choral music and here he brilliantly captures the solemnity and sense hope in these words:

Welcome Jesu,
Deep in my soul forever stay,
Joy and love my heart are filling
On this glad Communion day.

On the fourth Sunday of Advent, we'll hear Mark A. Miller's 2012 composition, *God has work for us to do*, with text by Carl Daw. Miller is on the faculties of the Yale Institute of Sacred Music and the Drew Theological Seminary and is highly regarded for composing anthems in a style that is both interesting and relatable to contemporary musical tastes. Many of Miller's pieces deal with issues of social justice, and in the theme of Advent, the text he chose for this piece is a reminder of our mission in the community and world at large:

'Til all the jails are empty and all the bellies filled; till no one hurts or steals or lies, and no more blood is spilled: God has work for us to do, 'til God's will is done and all things are made new, God has work for us to do! 'Til age and race and gender no longer separate; 'til pulpit, press, and politics are free of greed and hate: God has work... In tenement and mansion, in factory, farm and mill, in board room and in billiard hall, in wards where time stands still,.. In classroom, church and office, in shops, or on the street, in every place where people thrive, or starve or hide, or meet. God has work... By sitting at a bedside to hold pale, trembling hands, by speaking for the powerless against unjust demands. By praying through our doing, and singing though we fear, by trusting that the seed we sow will bring God's harvest near: God has work...

Advent

Lessons & Carols

With the St. James's Choir

*Featuring the Music of
Bach, Rachmaninoff, Bruckner*

*Sunday, December 7 at 5pm
St. James's Episcopal Church*

*A light reception will follow
Lessons & Carols*

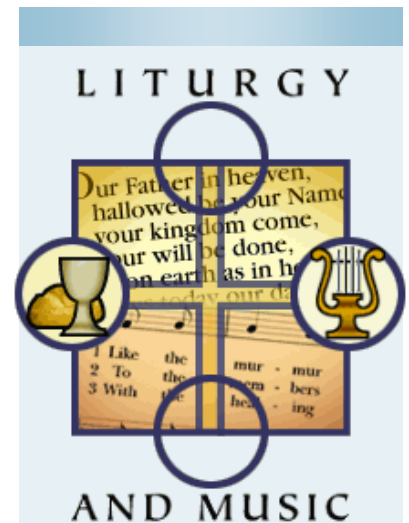

Important Dates

Sunday, December 7

Advent Lessons
& Carols at 5pm
in the church

*A light reception will follow
Lessons & Carols*

Christmas Eve December 24

Music Prelude, 10:30
Choral Eucharist, 11:00
with the full choir

Jubilate Deo!

**O be joyful in the
Lord all ye lands;
serve the Lord with
gladness and come
before his presence
with a song.**

Psalm 100:1

Bring a Friend to Church 6

Outreach at St. James's

Angel Tree 2014

WE ARE pleased to announce that the first of the name tags for gifts for Angel tree children are now available for your selection. This program offers a wonderful opportunity to bring the love of Jesus Christ to the children of prisoners during this special season of caring. (These are children who often don't understand why mommy or daddy can't be with them at Christmas. Some of the children are too young to even know what a prison is. They are the innocent and often unnoticed victims of crime.)

Incarcerated parents have few, if any, chances to show their love to their children at Christmas time. By giving a gift of a toy or clothing in the name of the absent parent, you can help to express this love which means so much to both the children and their parents.

The Angel Tree tags with the names of the children and their gift wishes will be available in the Cloister after Sunday services. Suggested cost of the gifts is \$25. Please bring your **wrapped and tagged** gifts to the church office by **Sunday, December 14**. Volunteers will deliver the gifts to the families during the week before Christmas. If you have questions or would like to volunteer, please call Barbara Schiller, at 860-651-7332. Thank you.



Toys! Toys!

ONCE again we are collecting toys for children in the Hartford area. Toys, games and fun gifts are needed for children of all ages from toddlers to early teens. These gifts will then be delivered to various churches who will then deliver them to the families in need. Please place your **unwrapped** gifts in the box at any of the three Church entrances by **Sunday, December 7**. Thank you for making Christmas a happier time for these families!



Poinsettia Sale

BEAUTIFUL Poinsettia plants will be available for purchase on **Sunday, December 14** after both the 8 and 9:30 services with a variety of colors to choose from. Just look for Doug Compton who will be running the sale.

Proceeds from the sale go to benefit the St. James's Feeding programs. Thank you!

Food Collection

PLEASE remember to bring a non-perishable item with you to St. James's each time you come to church! Look for the large, black bins around the building marked "non-perishable foods." Together, we can do a lot in the effort to stamp out hunger right here in our own community. Thank You!

Around the Parish

Adult Formation December 2014

December 7

INQUIRER'S CLASS—EPISCOPAL ETHICS

In the Parish Room

What do Episcopalians believe about war/violence, sexuality, abortion, and other major challenging topics of the day? More importantly, how do we believe we are to engage topics such as these?

December 14

WHAT ARE YOU READING?

In the Parish Room

Do you want to read a book but do not want to commit to an extended book study? Choose one of the books below and show up on in the parish room at 11am after having read at least a few chapters of your book of choice. We'll have some casual discussion about what you've read so far in this low-pressure, one-time event. A list of potential book discussion selections below (look in the Church Bulletin for others):

Why did Jesus, Moses, the Buddha, and Mohammed Cross the Road?

by Brian McLaren

Paradoxy, Creating Christian Community Beyond "Us" and "Them"

by Ken Howard

Velvet Elvis or Love Wins

by Rob Bell

Pastrix: The Cranky, Beautiful Faith of a Sinner & Saint

by Nadia Bolz-Weber

December 7, 14, 21

THE MANGER, MAGI, A STAR, ANGELS, SHEPHERDS, DONKEYS AND COWS: THE TRUTH AND THE MYTHS OF THE CHRISTMAS STORY

With Mark Evans in the Adult Education Room

What is the image that you have of that first Christmas long ago? Is it your typical manger scene with angels, shepherds, cows and donkeys, visiting Magi and a star overhead? What was it really like? How have the perceptions of this event changed over time? Join the discussion. *Come to one session or come to all.*

December 21

SOCIAL JUSTICE ISSUES IN HARTFORD? WHY SHOULD I CARE?

With Christopher Doucot in the Parish Room

Christopher Doucot and his wife Jackie operate the Hartford Catholic Worker, a lay community working and praying for an end to violence and poverty in Hartford. After preaching at the 9:30 service, Christopher will facilitate a discussion on justice issues around Hartford and how we can be more involved. Please join him for this thought-provoking session.

December 28

CHRISTMAS WEEK NO CLASSES OR COFFEE HOUR

Annual Reports

ANNUAL reports are due in by **Monday, January 5, 2015!** All reports will be bound together in one booklet for distribution one week before the annual meeting which will be held Sunday, January 25 following the 9:30 service. If at all possible, please email your report to help facilitate the organizing of all the information. The reports will be available on Sunday, January 18. Thank you for your cooperation!

Parish Office Closings

Christmas Eve, Dec 24

Christmas Day, Dec 25

Friday, Dec 26

New Year's Day, Jan 1

Friday, Jan 2

Articles for the January 2015 issue of SJ News are due Monday, December 15.

Bring a Friend to Church 8

Vestry Nominations 2015

THE Vestry Nominating Committee welcomes suggestions, from members of the parish, of persons who they believe would be fine members of our vestry and officers (Senior and Junior Warden, Treasurer and Clerk).

Vestry members must be:

1. committed to Jesus Christ;
2. regular in attendance at public worship;
3. participants in the life and ministry of the congregation;
4. solid financial supporters of our ministries;
5. be willing to commit to regular attendance at monthly meetings (the 3rd Tuesday), annual vestry retreats, and to serve as liaison with committees or programs within the parish.

The members of this year's Nominating Committee are: Doug Compton, Ron Coons, Ellen Dollar, and Chuck Willson. The Nominating Committee will publish its nominations in the January issue of *SJ News*.

In accordance with the by-laws of the church, any member may submit a petition to include any other member for inclusion on the ballot as a candidate for the vestry or as an officer. The petition must be signed by the nominating member, not less than three additional members of the parish and agreed to by the signature by the nominated member. All petitions are to be submitted to the Clerk no later than two weeks prior to the annual meeting to be held on **January 25, 2015**. Nominations not submitted as set forth will not be allowed from the floor at the annual meeting.

9 Bring a Friend to Church

Christmas Tree and Wreath Sale 2014

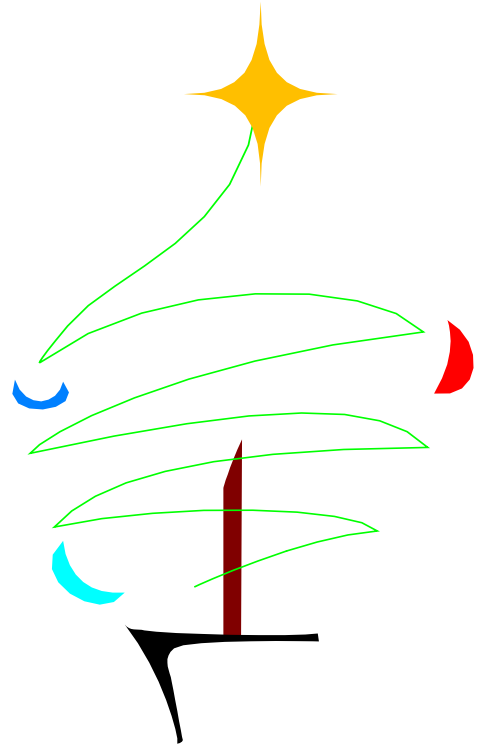

Friday, December 5 through
Sunday, December 14
at St. James's Episcopal Church
1018 Farmington Avenue
West Hartford Center
Phone: 521-9620; Fax: 521-5756
Email: info@stjameswh.org



We accept cash, check,
and all major credit cards!



First Friday Family Night

COME to First Friday Family Night on **December 5**



beginning at 5:30 in the Dining Room for something different to do on a Friday evening. Enjoy pizza, a movie for the kids, and fellowship with others from the parish. All are welcome! You don't have to be a parishioner to attend, so invite your friends! A \$10 donation is appreciated to help with the pizza, but not required. Beverage and a side will also be provided. Adults are welcome to bring their own beverage. Please RSVP to Deb Ross at dross2631@gmail.com if you plan to

Christmas Flowers

TO give Christmas flowers in honor or in memory of loved ones, please make your request with the names of each person, along with your donation using the envelopes at the end of the pews in the church and chapel. **Flower envelopes will be available beginning Sunday, November 30.** Please return your envelopes to the parish office no later than Friday, December 19. A list of those loved ones so honored or remembered will be included in the Christmas bulletins.

December Parish Birthdays

Children and Youth

Oliver Woodward, 4
Harry Lewis, 5
Blair Connelly, 7
Joshua Campbell, 10
Leah Dollar, 10
Braden Flowers, 12
Zoe Pinckney, 14
Hayley Welch, 14
Jacob Ciccone, 18
James DeLibero, 18
Frances Cox, 19
Rowan Guerraz, 21
Andrew Stafford, 23
Emily Lemanski, 25
Claire Sherrill, 25
Ethan McCue, 29

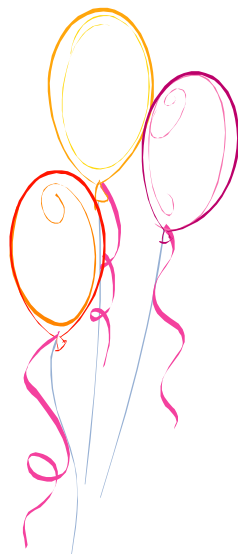

Crosstones to Perform at SJ

On **Saturday, December 13**, Crosstones, the oldest co-ed a capella group from Bates College, will be performing at St. James's! Founded in 1996, the Crosstones are known for their down-to-earth nature, humor, and energy. They have been performing both nationally and locally for over 15 years, and perform songs from all genres, ranging from Motown to pop to classic rock. Crosstones has been featured on a national CD billed as "The Best of College A cappella," ("BOCA") compiled by an independent group.

Local group members include Brett Ranerri, a graduate of Hall, Bobby Lankin, a graduate of Conard, and Luke McNabb, a graduate of Glastonbury High School. In addition, the group features several other fine college a cappella singers from all over the country. As a special treat for the evening, Be S#arp, a student run award-winning a cappella group from Conard High School will be opening the concert with several self-arranged selections. Singers from Be S#arp include Nora Dynowski and Avery Schott from St. James's, and other special guests.



CONCERT DETAILS

Date: Saturday, December 13
Place: St. James's Episcopal Church
Time: 4:30pm (about one hour)
Cost: Free (donations accepted)

Greening of the Church

CALLING all able-bodied men and women to help with St. James's annual greening of the church. Come and share in the preparations of the sanctuary for the coming of our Savior Jesus Christ. Please join Mary Ann Haar in the church on **Tuesday, December 23 at 3pm.** Your help is very much appreciated!



Sunday Lectionary

First Sunday of Advent, November 30

Isaiah 64:1-9
Psalm 80:1-7, 16-18
1 Corinthians 1:3-9
Mark 13:24-37



Second Sunday of

Advent, December 7

Isaiah 40:1-11; Psalm 85:1-2, 8-13
2 Peter 3:8-15a; Mark 1:1-8

Third Sunday of Advent, December 14

Isaiah 61:1-4, 8-11
Psalm 126 or Canticle 3 or Canticle 15
1 Thessalonians 5:16-24; John 1:6-8, 19-28

Fourth Sunday of Advent, December 21

2 Samuel 7:1-11, 16; Canticle 3 or Canticle 15
or Psalm 89:1-4, 19-26
Romans 16: 25-27; Luke 1: 26-38

Christmas Eve & Day, December 24, 25

Isaiah 9:2-7; Psalm 96
Titus 2:11-14; Luke 2:1-14(15-20)

Parish Prayer List

Those in our parish family:

Jeffrey, Greg, Justin, Joan, Ann, Michael, Michelle, Audrey, Claire, Nicole, Margaret, Ruth, Mae, Ruth, Anne, Donna, Julia, Brian, Sue, Natalie & Harry, John, and Stuart.

Those in our extended parish family:

Maria, Pam, Kevin, Mary Ann, Jenifer, Nancy, Jeff, Ashley, Carol, John, Margaret, Katherine, Christina, Jean, Jeff, Roger, Mario, Jennifer, Leslie, John, Justin, Karen, Bea & David, Heather, Liz, Bryan, Robert, Sarah, Corey, Claudia, David, Carol, Christine, Patricia, Bob, Jessie, Ryan, Lizzy & Taylor, Richard, Dick, Alice & Vito, Linda, John, Quinn, Arroll, Chris, Joanie, Rob, Teresa, Dave, Alvin, Betsy, Karen, Bob, Audra, Parker & Cynthia, Mary, Jackie, Tom, Ted, Olivia, Brent, Kaitlyn, Ann, Kara, Anna, Henry & Irene, Jinah, Patricia, and Jonathan.

Those Serving in the Military:

Andrew Clark, Michael P. Clarke,
Eric James Burgess, Mark Ulrich, Julian C. Barker,
Andrew Huntsman, and Ed Vera.

Women Of St. James's



Programs for December 2014

Tuesday, December 2

Rabbi Donna Berman, Director
The Charter Oak Cultural Center

Tuesday, December 9

Vaughn Mauren, Organist & Choirmaster
St. James's Episcopal Church
Music for Christmas

Saturday, December 13

HOLIDAY TEA
In the Parish Room from 2-4pm
(Snow date: December 14)

December 16, 23 and 30

No Meetings—Christmas and New Year Hiatus

Holiday Tea & Bake Sale

Saturday, December 13 from 2-4pm

CELEBRATE this festive season with a traditional afternoon tea featuring Harney & Sons tea accompanied by an assortment of delicious homemade scones, savory tea sandwiches, sweet pastries and more.

Don't miss out on our renowned Holiday Bake Sale featuring artfully wrapped homemade treats, and shop our offering of artisan-made beaded Christmas ornaments.

Tickets on sale in the Church Office, at the door, and beginning **November 23**, after the 9:30am service during coffee hour. \$10 for adults and \$8 for children 10 and under.

Women's Evening Group

ALL women of the parish and their guests are invited to an evening of relaxation, wine, and good food on **Thursday, December 11** at 6pm in the Parish Room. We begin with a half-hour social followed by a potluck supper. Please bring your choice of an appetizer, main dish or casserole, vegetable, or a dessert to share with the group. Questions or to RSVP, please contact Sue Nelson at 860-232-8157. Invite a

The Clergy

The Reverend Robert C. Hooper, III	Rector
The Reverend Curtis A. Farr	Assistant Rector
The Reverend Canon Douglas T. Cooke	Priest Associate
The Reverend Dr. Molly O. Louden	Priest Associate
The Reverend Dr. Borden W. Painter	Priest Associate
The Reverend Elsa P. Walberg	Priest Associate
The Reverend Terry M. Wysong	Priest Associate

The Staff

Heidi Cotter	Financial Secretary
Cheryl C. Batter	Administrator
Priscilla Hooper	Director of Religious Education
Randall Martini	Sexton
Vaughn Mauren	Organist & Choirmaster

The Vestry

Ann Cooke	Senior Warden
David Dynowski	Junior Warden
Ollie Bunch	Clerk
Michael Sherrill	Treasurer
Richard M. Wenner	Assistant Treasurer
David Thomas	Facilities Manager

Term Ending 2015

Doug Compton, Ron Coons
Ellen Dollar, Chuck Willson

Term Ending 2016

Michael Fitzsosa, Carol McDermott
Eleanor Michael, Peter Peterson

Term Ending 2017

Kathy Bolt, Ben Parish
Michael Shuey, Judith Stahl

St. James's Episcopal Church

19 Walden Street
West Hartford, CT 06107

Phone: 860-521-9620

Fax: 860-521-5756

E-mail: info@stjameswh.org

Website: www.stjameswh.org

Address Service Requested

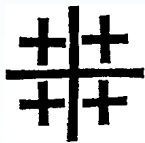

NON-PROFIT ORG.
U.S. POSTAGE
PAID
Permit 3071
Hartford, Conn.