

St. James's

EPISCOPAL CHURCH
West Hartford Center

October 2014

From the Rector's Study

"Gospel Math"

But each of us was given grace according to the measure of Christ's gift.... The gifts he gave were that some would be apostles, some prophets, some evangelists, some pastors and teachers, to equip the saints for the work of ministry, for building up the body of Christ, until all of us come to the unity of the faith and of the knowledge of the Son of God, to maturity, to the measure of the full stature of Christ.... But speaking the truth in love, we must grow up in every way into him who is the head, into Christ, from whom the whole body, joined and knitted together by every ligament with which it is equipped, as each part is working properly, promotes the body's growth in building itself up in love.

Ephesians 4:7,11-12 &15-16

A COUPLE of weeks ago my sermon included the idea that the Bible can be seen as a user's manual to a life lived in community and in God's vision, or what Verna Dozier (contemporary theologian and writer) used to call "God's Dream." The fourth chapter of Paul's letter to the Ephesians encapsulates this idea beautifully. This letter is primarily a celebration of the life of the Church as a unique community established by God through the work of Jesus. It teaches us that the Kingdom of God, and by extension, the Church, is greater than the sum of its parts. In other words, we can do far more together in the name of Christ than we could ever do individually. This is what I like to call "Gospel Math." While we learn in school that $1+1=2$, and popular culture and politics seem to prefer to use the math of scarcity, "Gospel Math" is about abundance.

The letter to the Ephesians tells us in no uncertain terms that we have been given all that we need to do the work of the faithful, to build up the Church in love and through this each other and the worlds we live in. We are *all* equipped, with different skills and gifts, and joined together by the very reality that we are the beloved children of God, to hear and heed the Gospel call, to share the love of Christ and to live into that love. The Grace of God and the love of Christ are perfect examples of this "Gospel Math." In sharing, in the very act of giving them to others, they grow and multiply in us.

We build up the Church by building up others. To do this, however, we must be spiritually grounded through a life and practice of prayer and study. What are you doing to take care of yourself, of your heart and your soul? What are you teaching your children? How can we, as a community of folks struggling to be faithful, lift you up and journey with you along the way? As the conversation here at St. James's continues about how we are called to go deeper in faith together and as individuals, I hope that you will be a part of this. Share your thoughts, your dreams and your prayers. Be a part of the liturgy, of wonderful formation opportunities for young and old alike and the wider life of the parish this fall and let us, like Paul, celebrate this grace filled and divine gift that we call the Church, the Body of Christ.

Faithfully,

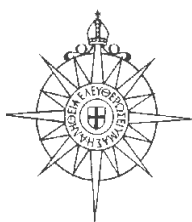
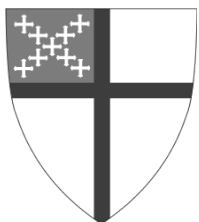

To Learn, Live and Teach the Values of
the Gospel of Jesus Christ

Treasurer's Report

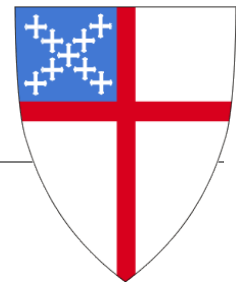

St. James's Treasury Report Reported Results Year to Date through August, 2014

Current Position: In the three months since the prior financial report was distributed to the parish, the church's financial position has improved. As seen in the table below, the finances are now \$5,377 better than expected through the end of August. This compares to a \$11,835 shortfall as of the end of May. The primary reason for the improvement is expenses that are more than \$11,500 less than budgeted through this point in the year. At the end of May, expenses were \$1,000 above budget. While income continues to trail its budgeted figure, the last three months have seen an improvement in this figure as well. At the end of May income was \$10,749 below budget. It is now \$6,160 below budget. Expense monitoring will continue during the final third of the year.

Income & Expense Summary:

Category	YTD Actual	YTD Budget	YTD Variance	Total Annual Budget
Income (+)	\$493,792	499,952	6,160 Below plan	764,300
Expense (-)	497,641	509,178	11,536 Below plan	764,300
<i>Net</i>	(3,849)	(9,226)	5,377 Positive variance to budget	0

Income: Year-to-date (YTD) actual income is \$6,160 below budget (or 1.2% worse than budget). This figure is an improvement from May's income figure that trailed the budgeted figure by \$10,750 (3.0% of budget).

Expense: YTD expenses experienced a significant improvement during the summer months. As of the end of August, expenses were \$11,537 below budget; this difference represents 2.3% of the budgeted amount. Expenses were \$1,100 (or 0.3%) above budget at the end of May.

Inside this Issue	Page #
From the Rector's Study	Cover
Treasurer's Report/What's Inside	2
From the Assistant Rector	3
St. James's Center for Children	4-5
Music & Liturgy	6
Outreach	7
Around the Parish	8-12
Women of St. James's	13-14
October Calendar	15

Important Dates to Remember!

- Friday-Sunday, Oct 10-12** - Confirmation Retreat!
- Friday & Saturday, Oct 17 & 18** - Women of St. James's Fall Rummage Sale!
- Wednesday, October 22** - Boys & Girls Choral Evensong in the church at 6pm!
- Friday & Saturday, Oct 24 & 25** - Diocesan Convention!
- Sunday, October 26** - Rhythms of Grace at 4pm and Youth Second Sundays at 5:30pm! (On the fourth Sunday, this month only.)
- Friday, October 31** - Youth Haunted House Event!
- Saturday, November 1** - Parish Auction at 7pm!
- Sunday, November 2** - All Saints' Sunday (one service at 10am) and Annual Stewardship Brunch!

From the Assistant Rector

Dear Sisters and Brothers,

Rather than risk contracting a virus from the latest issue of People Magazine, from which Jill and Derick of '19 Kids and Counting' stare at me promising to enthrall me with details of their newest child, I am contemplating the idea of a check-up.

Yes, I'm at the doctor's office.

A year ago, I was in this chair, eagerly waiting to utilize my newly established health insurance. I was new to St. James's, and I was new to domestic bliss with now-husband Antonio.

What an adventure this year has been!

But I won't reflect on that now. Instead I want to share with you one of the most precious rituals Antonio and I share with each other. Every Sunday night, as we're getting ready for bed, Antonio and I ask each other four questions; we haven't missed a week in more than two years. Even if we're not particularly happy with one another, we find common ground in that ritual.

Essentially, our relationship gets a check-up every week.

The four questions, since you're curious by now, are:

How did I make you feel loved this week?

What do you have coming up this week?

How can I make you feel loved this week?

How can I pray for you this week?

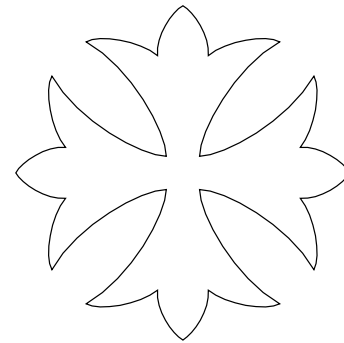

It's this kind of inventory that helps us to keep to a similar

rhythm.

I find the same model of introspection to be useful in prayer. I don't currently have a spiritual director, but I have before and I will again. One of the things I do in spiritual direction is take stock of where I've been and where God has been in my relationships and activities. I intentionally look for ways in which God dances around in my life, and then I try to prepare myself to be a better dance partner.

I recently had a conversation with someone who steadily contemplates prayer but struggles to find traditional modes of prayer to be useful or relevant. As we talked about life's challenges, bewilderments, and joys, we discovered that our conversation itself had taken the form of a prayer.

Prayer is, of course, more than a spiritual checkup, but a visit to the doctor can be analogous to checking in with a loved one and with God. Some basic questions need to be asked. Sometimes there are things we need to change (our diets, medications, exercise habits, or into a hospital gown, as is currently the case), and sometimes we discover something new about ourselves that helps us along the path to wholeness.

Many of us are already caught up in the business of the program year; it's harder to take stock right now, and that means it's super important. So sit down on one of these cool, crisp mornings and try a little prayer—whatever form it takes.

Your Brother in Christ,

St. James's Center for Children

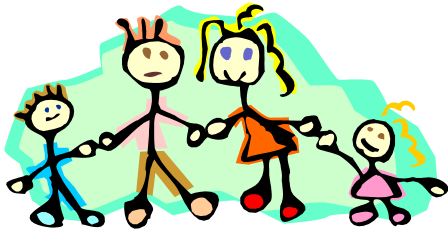

*nurturing your children's spiritual life
from birth through high school*

WHEN I begin to write my newsletter articles each month, I always look back at past years just to help spur on my writing. When I looked back at my writing last October, I wrote about how much I love October in New England. I moved to New England to begin my life with Bob 28 years ago this month. My Dad drove me up to New Hampshire and the further north we got the more I fell in love with New England. The fact that I am still fortunate enough to live here, makes me happy every single day, especially in autumn. It is amazing and my favorite time of the year.

This year, I am most excited about the great program year ahead at St. James's. There is a terrific energy here this month and I am so thankful for all the people who have said, "yes," to me when I have come calling for volunteers for Sunday school and youth group. All of you are what make this place so special.

This past Sunday, was the first Sunday of the program year. We had a volunteer fair. We had our first Sunday of Sunday school. We had a huge turnout in the choir and in kid's liturgy. The whole church was buzzing with the possibilities of this amazing place.

We also began our Second Sundays Youth Group this past Sunday. We had a wonderful group of high school and middle school students as well as some great volunteers take part in a scavenger hunt around West Hartford center. It was a great time for all involved. In October, we will have Second Sundays on the fourth Sunday of the month which is October 26 instead of the second. On Halloween night, October 31 we will have a haunted house here at the church. It should be a spooky good time for everyone! If you are in high school or middle school, please join us on October 26 to help get ready for Halloween. As always we will have dinner at 5:30, then get to work. Get your homework done early so you can join us!

On October 26 we will also return to Rhythms of Grace, a liturgical experience for children with different needs. We began offering Rhythms of Grace last winter and it has been an amazing experience. Just for the month of October, it will happen on the fourth Sunday. In November it will take place at its regularly scheduled time of 4:00 on Second Sundays, November 9 in the parish hall.

Also new this fall is a completely redone Godly Play Room! In September, parishioners Jonathan Lewis and Emily McMurray did a complete overhaul of the room including new white boards, organizational system and paint. It looks amazing! Thanks to all who were involved in that project including those who had input into the changes that should be made—Eleanor Michael, Abby Fisher-Williams and Adam Fisher.

So, there is a lot to be thankful for around here this fall! I hope and pray that we can all make the most of the opportunities here. There is so much going on and so many great programs for people of all ages from the youngest to the oldest. Come and join us!

Your sister in Christ,

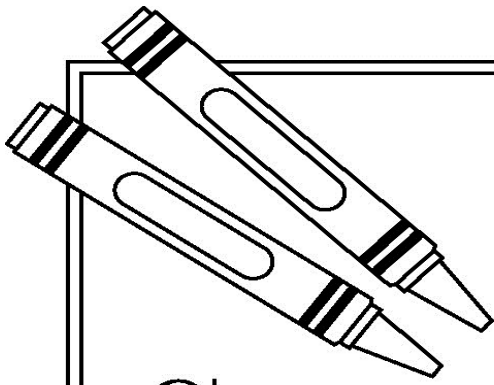

Just for **KIDS**

Search for Wisdom

It's the start of a new school year! You'll learn many things and read many books. There's an important book in the Bible called the book of Proverbs. It tells us to learn about God and to search for wisdom.

Read Proverbs 2:1-5 (NIV) below, and then search the puzzle for the capital words.

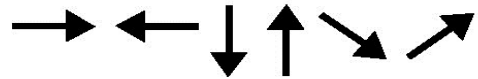

“... if you **ACCEPT** my words and store up my **COMMANDS** within you, turning your **EAR** to **WISDOM** and applying your **HEART** to **UNDERSTANDING**, and if you call out for **INSIGHT** and cry aloud for understanding, and if you **LOOK** for it as for **SILVER** and **SEARCH** for it as for hidden **TREASURE**, then you will understand the fear of the **LORD** and find the **KNOWLEDGE** of **GOD**.”

U	F	R	P	Q	X	I	X	H	E	A	R	T
D	N	R	D	X	R	M	P	F	I	C	O	E
H	A	D	I	Z	O	I	P	J	E	B	G	X
E	G	G	E	D	C	R	N	R	J	D	P	H
S	Y	U	S	R	E	O	U	S	E	O	C	I
E	U	I	E	V	S	S	M	L	I	Y	K	B
A	W	K	L	D	A	T	W	M	H	G	Z	P
R	X	I	P	E	T	O	A	K	A	C	H	L
C	S	D	R	P	N	J	G	N	N	N	E	T
H	J	T	J	K	O	N	O	V	D	W	D	K
H	U	Y	N	L	O	R	D	O	S	I	O	S
Z	X	Z	A	G	X	C	Z	M	U	O	N	J
A	C	C	E	P	T	S	Y	D	L	E	D	G

From the Organist/Choirmaster

AS THE choirs and I have settled into our second week of rehearsals, I've been thinking a lot about the role our institution plays in greater Hartford. What do we offer people and with whom do we share it? It's hard not to reflect on what makes St. James's unique because I've been a part of so many other parishes, beginning with my chorister days at the Cathedral of All Saints in Albany and through many other formative experiences at parishes of all kinds.

St. James's has so much to offer the greater Hartford area. Our Sunday morning services are vibrant and energetic and our weekday programs are strong and active. We also share the resources of our abundant space with the surrounding community. For these reasons, we are truly a community-centered church. People from all walks of life come through our doors each week to be fed in one way or another.

As your music director, my role at St. James's is complex because I am charged with overseeing a music program that adheres to the needs of a diverse people who pass through the red doors on Sunday morning – people who've experienced a wide swath of musical traditions before coming to our parish. My first priority with the choir and my own organ playing will always be to present the Episcopal music tradition at its highest possible level because it is at the heart of who we are. However, I also want to program music outside of the Anglican tradition because as a suburban Connecticut parish in the year 2014, we must provide worship resources that reflect the people of our time and place.

Last year, I had the great fortune of playing a service for which the Rt. Rev. Neil Alexander, Dean of the School of Theology at Sewanee, was the preacher. Neil is both a brilliant preacher and liturgist, and he recently gave a talk to the Diocese of Southwest Florida in which he addressed the difficulty and importance of presenting our traditional way of worship in a rapidly changing society: "Rituals are memory-laden, time-sensitive, a repeatable action that is chosen, not required, but is missed if one fails to do it." He then added that to keep a tradition, it must not be too fixed: "Tradition is always moving, and a viable tradition is actually quite fluid, but you've got to honor the skeleton."

Here at St. James's, Bob, Curtis and I share these ideas about liturgy and music; we believe that traditions are at the heart of who we are as a church but that they must remain moving. Whenever we introduce new music or prayer, we do so to keep our worship both relevant and vibrant. I hope you find the work we put into this will help you experience an even more fulfilling Sunday morning.



Bring a friend to church, page 6

LITURGY



AND MUSIC

Important Dates to Remember

Wednesday, October 22

Boys & Girls Choral Evensong

**IN THE CHURCH AT 6PM
(ALL ARE WELCOME!)**

Sunday, November 2

**All Saints' Sunday
One Service at 10am
Followed by the Annual
Stewardship Brunch**

Jubilate Deo!

**O be joyful in the
Lord all ye lands;
serve the Lord with
gladness and come
before his presence
with a song.**

Psalm 100:1

October and November Outreach ... Intergenerational Event

“Let’s Stuff Stockings!”

HELP MAKE a difference at Christmas for the men at two area shelters – the Open Hearth and Salvation Army. St. James’s Outreach has been collecting warm socks and toiletries for the men at the Open Hearth and the Salvation Army shelters in Hartford since 1989. The October and November Outreach project is collecting men’s socks and toiletries which we will assemble on the First Sunday of Advent, **November 30**, after the 9:30 service. These stuffed socks are often the only holiday gift these men receive.

Requested stuffer items are: **sample-size (small)** personal care products such as pocket combs, toothpaste, tooth brushes, deodorant, shaving cream, skin cream, nail files, nail clippers, non-alcoholic mouthwash, shampoo, disposable razors and sample size soaps. We are also collecting **warm, thick men’s socks**. We could also use some candy canes to add an additional holiday touch to the socks. Please bring your donations to the church and place them at any of the entrances to the church. Thank you!

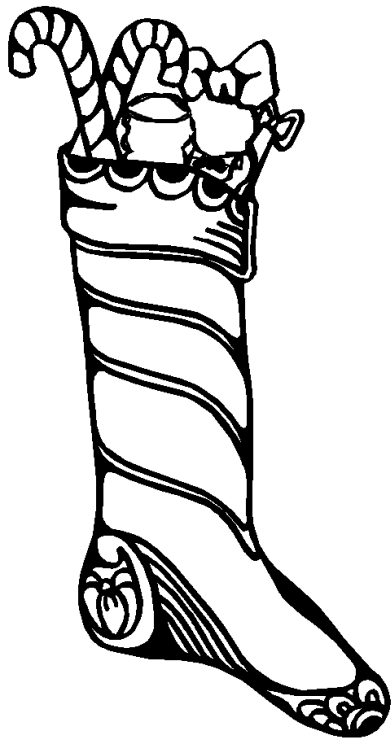

16th Annual School Supply Drive Update!

ST. JAMES’S parishioners donated 22 boxes of school supplies and backpacks to The Hartford Catholic Worker Project, The Place of Grace Food Pantry and The Bridge Family Center. The agencies distributed the learning tools to the children they serve in programs in Hartford and West Hartford. Thanks to your generosity many children started off the school year well prepared.

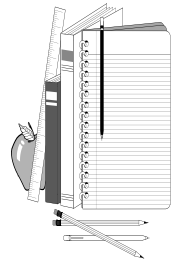

Apple and Pie Sale—Round II Sunday, October 5

THE apple and pie sale held recently on Sunday, September 14 was a big success; so much so that Doug Compton ran out of pies! If you wanted a pie and did not get a chance to purchase one, you’ll have another opportunity on **Sunday, October 5**. Doug will be selling farm fresh apples and pies as well as a couple of other farm fresh fruits after both the 8 and 9:30 services. Pies will be available in choices of apple or fruit of the farm.

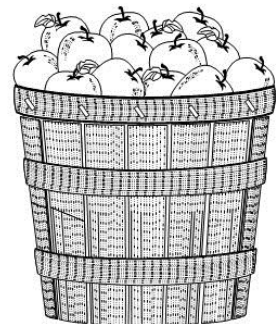

All proceeds go to benefit the St. James’s Feeding programs.

Food Collection ...

PLEASE remember to bring a non-perishable item with you to St. James’s each time you come to church! Look for the large, black bins around the building marked “non-perishable foods” or place the items in the wagon located in the cloister. Thank You!

Around the Parish

CHRISTIAN EDUCATION AND FORMATION

October 2014

Sunday, October 5

A Pilgrimage in Spain

With The Rev. Bob Hooper in the Parish Room

BOB recently walked El Camino De Santiago in Spain. Hear about his journey as he shares stories and images of this beautiful part of the world.

Sundays, October 5, 19, and 26

Ruby, Emerald, Topaz, and Carbuncle—Gems and Minerals in the Bible

With Mark Evans in the Adult Education Room

BRIGHT, colorful and rare, gems, precious metals, and minerals made a lasting impression on ancient cultures. There are dozens of references to them throughout the Bible. In these sessions, we will examine many of these materials, why they were important from a historical context, and their meaning. Come and learn with us. Come to one session or come to all.

Sundays, October 19 and 26

BOOK STUDY: *The Righteous Mind* Why Good People are Divided by Politics and Religion

With Beth Richards and the Rev. Terry Wysong in the Parish Room

IN THIS book, Jonathan Haidt challenges conventional thinking about morality, politics, and religion in a way that speaks to everyone on the political spectrum. Drawing on his twenty-five years of groundbreaking research on moral psychology, he shows how moral judgments arise not from reason but from gut feelings. He shows why liberals, conservatives, and libertarians have such different intuitions

about right and wrong, and he shows why each side is actually right about many of its central concerns. (Excerpted from Amazon.com)

Please order the book early. Beth and Terry will suggest chapters to focus on. It is available in Kindle format (\$9.72) and paperback (\$10.23) from Amazon. Other online retailers will also have it available.

Sunday, October 26

INQUIRERS' CLASS

Episcopal Beliefs

With The Rev. Curtis Farr in the Library

THE Episcopal Church been called a “Big Tent” regarding our beliefs. Learn about the characters under this tent as we explore the major theological viewpoints within the church.

Sunday, October 12

Columbus Day Weekend-No Classes

Parish Wide
Stewardship
Brunch!



All Saints' Sunday
November 2
After the 10 o'clock service
(No 8:00 service)

*Don't miss the annual Stewardship Brunch!
A chance for all of us to come together to share
in a tasty brunch and give thanks for all God
has done in our midst. Please bring a
breakfast casserole or another breakfast item to
share with the group, if you are able.*

Mark Your Calendar!

The St. James's AUCTION

Saturday, November 1

Drinks, Dinner,

Silent Auction, Live Auction

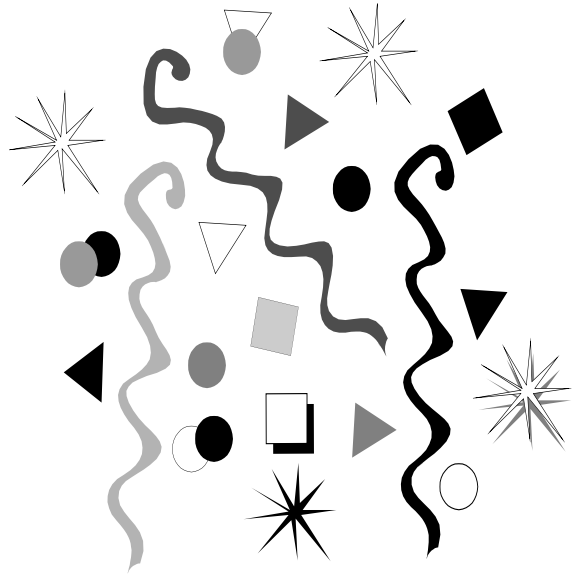

Mark your calendar for an evening of fellowship, food, and great finds all for the benefit of the ministries of St. James's.

Donations - Do you have an item to donate? A special skill? We're looking for all kinds of things—vacation rentals, handcrafted goods, baking services, gift cards, wine, professional services, etc. Part of what makes the auction so special are the unique and interesting contributions from our gifted and thoughtful parishioners.

Volunteers—Are you interested in participating in the planning or helping during the auction? You can help a little or a lot, and have fun doing it!

Contact **Deb Ross** (dross2631@gmail.com) or
Samantha Dynowski (dynowski@comcast.net).

HALLOWEEN...

HAUNTED HOUSE!



Calling all children 7 and overrrrr...
Come to the Haunted Hooouuse...

Be prepared to be spooked and scared silly!

Friday, October 31 (early evening)
St. James's Church (Walden St Entrance)
Be there...if you dare



Rhythms of Grace

Rhythms of Grace -- a worship and faith formation experience for children and families with special needs will be held on **Sunday, October 26** at 4PM at St. James's Episcopal Church in West Hartford! Rhythms of Grace is held every second Sunday of the month, however, for the month of October only, it will be held on the fourth Sunday.

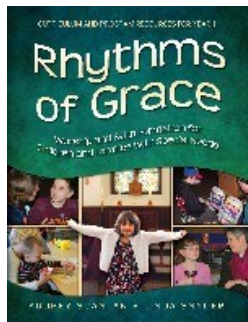

Rhythms of Grace combines a sensitive, mindful celebration of the Holy Eucharist with a wealth of developmentally appropriate, experience-based activities.

For more information, please contact Priscilla Hooper at (860) 521-9620 or go to the website www.rhythms-of-grace.org to learn more.

First Friday Family Night

COME to First Friday Family Night on **October 3 beginning at 5:30** in the Dining Room for something different to do on a Friday evening. Enjoy pizza, a movie, a craft for the kids, and fellowship with others from the parish. A \$10 donation is appreciated to help with the pizza, but not required. Adults may choose to bring their own beverage.

Please RSVP to Deb Ross at dross2631@gmail.com to let her know how many in your family will be attending.



Women's Evening Group

ALL women of the parish and their guests are invited to an evening of relaxation, wine, and good food on **Thursday, October 9 at 6PM** in the Parish Room. We begin the evening with a social half-hour followed by a potluck supper. Please bring one of the following to share with the group: an appetizer, main dish or casserole, vegetable, or a dessert. Questions or to RSVP, please contact Sue Nelson at 860-232-8157. Invite a friend to join you!

Youth Group Second Sundays

Sunday, October 26

YOUTH (6th-12th grade) who come to youth group on **Sunday, October 26** will leave the building more haunted than they found it. We'll eat at 5:30 and then spend the evening preparing the halls of St. James's for a haunted house, which will open to trick-or-treaters on Halloween. Pick up is at 7:30. Do your homework early and invite your friends!

Don't Forget!
Daylight Savings
Time Ends
November 2

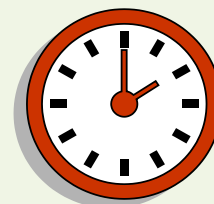

We turn our clocks back one hour Saturday evening November 1

Newsletter deadline

Articles for the November 2014 issue of the *St. James's Newsletter* are due **Wednesday, October 15**

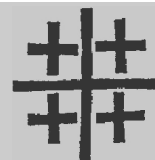

Office Closings

The parish office will be closed for the **Columbus Day Holiday on Monday, October 13**

Sunday Lectionary

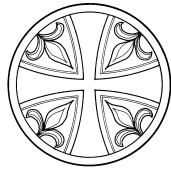

Seventeenth Sunday after Pentecost, Oct 5

Exodus 20:1-4, 7-9, 12-20, Psalm 19
Philippians 3:4b-14; Matthew 21:33-46

Eighteenth Sunday after Pentecost, Oct 12

Exodus 32:1-14; Psalm 106:1-6, 19-23
Philippians 4:1-9; Matthew 22:1-14

Nineteenth Sunday after Pentecost, Oct 19

Exodus 33:12-23; Psalm 99
1 Thessalonians 1:1-10; Matthew 22:15-22

Twentieth Sunday after Pentecost, Oct 26

Deuteronomy 34:1-12; Psalm 90:1-6, 13-17
1 Thessalonians 2:1-8; Matthew 22:34-46

Parish Prayer List

Those in our parish family

Jeffrey, Greg, Justin, Joan, Ann, Michael, Michelle, Audrey, Claire, Nicole, Margaret, Ruth, Mae, Ruth, Anne, Donna, Julia, Brian, Sue, Natalie & Harry, John, and Stuart.

Those in our extended parish family

Maria, Pam, Kevin, Mary Ann, Jenifer, Nancy, Jeff, Ashley, Carol, John, Margaret, Katherine, Christina, Jean, Jeff, Roger, Jean, Mario, Jennifer, Leslie, John, Justin, Karen, Bea & David, Heather, Liz, Bryan, Robert, Sarah, Corey, Claudia, David, Carol, Christine, Patricia, Bob, Jessie, Ryan, Lizzy & Taylor, Richard, Dick, Alice & Vito, Linda, John, Quinn, Arroll, Chris, Joanie, Rob, Teresa, Dave, Alvin, Pat, Betsy, Karen, Bob, Audra, Michael, Parker & Cynthia, Mary, Jackie, Tom, Ted, Olivia, Brent, Kaitlyn, Ann, Kara, Anna, Henry & Irene, Jinah, Patricia, Pamela, and Jeffrey.

Those Serving in the Military

Andrew Clark, Michael P. Clarke,
Eric James Burgess, Mark Ulrich, Ed Vera,
Julian C. Barker, and Andrew Huntsman.

Parish Birthdays Children & Youth

OCTOBER

Meg Dollar, 3
Lucia Paul, 3
Roman Tagliarini, 3
Katherine Morriss, 7
George McGarry, 8
Charlotte Burns, 11
Jacob Campbell, 23
Lucas Butts, 31
Nia Fraser, 31

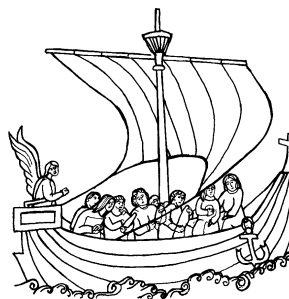
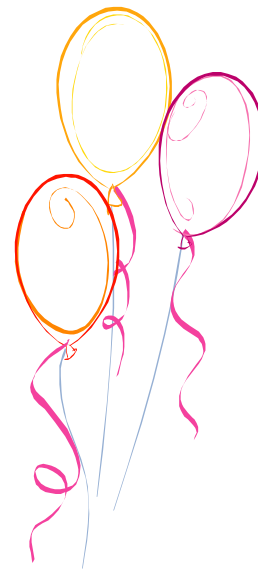

All Saints' Sunday November 2, 2014

One Service Only
At 10:00 in the
Church

Followed by the
Annual Stewardship Brunch in the
Dining Room
(No 8am service)

Parish Registry

Baptisms

Jens Duus Rasmussen
Son of Peter and Meghan Rasmussen
September 21, 2014

Deaths

Virginia Costello
August 18, 2014
Thelma Long
September 1, 2014

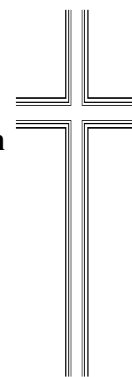

Women of St. James's

Welcome Back to the WOSJ!

WE will begin a new program year on Tuesday, October 7 when our guest speaker will be the rector, the Rev. Robert C. Hooper, III. Bob will speak on his walk along the Camino de Santiago in Spain which he took during his sabbatical this past spring. He has many wonderful and funny stories to share—don't miss it! To the right is a listing of all the October programs and events. If you would like a copy of the program booklet for 2014-15, please phone the parish office.

Tuesday, September 30

WOSJ Executive Board Meeting at 10am

in the Parish Room followed by an informal gathering in the dining room with the Rev. Bob Hooper and the Rev. Curtis Farr

All are welcome—please bring a bag lunch

Holiday Tea Meeting

ANOTHER meeting to plan this year's Holiday Tea will be held on **Thursday, October 9** at 7:30PM in the dining room. All who are interested in helping to plan this event should attend the meeting. This year's tea will be held on **Saturday, December 13** from 2 to 4 in the afternoon. Snow date is December 14.

October 2014 Programs and Events

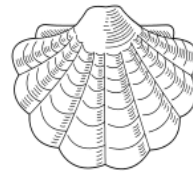

Tuesday, October 7

The Rev. Robert C. Hooper, III, Rector
The Camino de Santiago—Walking 500 miles across Spain and through history

Tuesday, October 14

Petra Shearer
Horses are Therapeutic Magic

Friday & Saturday, October 17 & 18

Fall Rummage Sale
Friday Sale 6:30 to 8:30pm
Saturday Sale 9am to 12noon

Tuesday, October 21

The Rev. Curtis A. Farr, Assistant Rector
Youth Mission Trip to the Dominican Republic

Tuesday, October 28

Amistad Art Exhibit and Lunch at the University of St. Joseph, West Hartford
Please bring a bag lunch, beverage provided
(Departure from St. James's Parking Lot)

Save the date!

Holiday Tea
Saturday, December 13
2-4 in the Afternoon

Snow Date:
December 14

Harney's Teas
Homemade Scones

Tea Sandwiches, Pastries, Crafts,
And our Traditional Holiday Bake Sale!
Along with a raffle for Holiday Items!

Fall Rummage Sale
Friday, October 17 and Saturday, October 18, 2014
Fall Cleaning Time

Fall is here and we are planning for the rummage sale in October. Here are some guidelines as you begin gathering items for the sale:

- ✦ ***Items may be brought to the church basement beginning Saturday, October 11.***
Please do not bring anything in before that date.
- ✦ Shoes need to be new or nearly brand new.
- ✦ TV's (**made after 2004**), computers and any other electronic equipment **must** be in working condition.
- ✦ Separate your rummage by category and label your boxes/bags accordingly; i.e. women's, men's, boys, girls, infants, books, shoes, etc.
- ✦ Bring hanging clothes (dresses, suits, blouses, shirts, coats) on hangers to be hung on available racks.
- ✦ Please be selective when sorting your rummage. We ask that everything be clean and in good repair. **Please, no stuffed toys or large exercise equipment.**
- ✦ **Small furniture – Useable and in good condition.**
- ✦ We cannot sell cribs. Because of limited space, we cannot take large exercise or ski equipment. Finer items will be sold in the "Boutique".

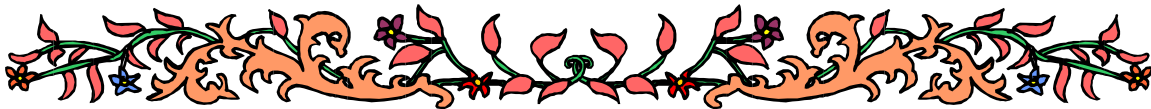

We also need your help before, during and after the sale. Volunteers are needed for:

- | | |
|-------------------------------------|---|
| Sorting: Friday, October 17 | 9 AM to 5PM Come for as long as you are able |
| Pre-Sale: Friday, October 18 | 6:30 to 8:30 PM <u>\$5 Admission.</u> Public and Parish is welcomed. |
| Sale: Saturday, October 18 | 9 AM to 12 Noon <u>Free Admission - optional \$5 and \$10 bags.</u> Public and Parish are welcomed.
12-12:30 PM - Cleanup immediately following sale. |

Please call Cindy Welch at 860-561-5560 to volunteer or if you have questions. Sign-up sheets will be available in the weeks preceding the sale.

The Women of St. James would like to thank all of you in advance for helping with the sale. So many of you contribute items and volunteer your time to make this sale a success every year. Without all of you, this would not be possible. Thank you very much!

The Clergy

The Reverend Robert C. Hooper, III
The Reverend Curtis A. Farr
The Reverend Canon Douglas T. Cooke
The Reverend Dr. Molly O. Louden
The Reverend Dr. Borden W. Painter, Jr.
The Reverend Elsa P. Walberg
The Reverend Terry M. Wysong

Rector
Assistant Rector
Priest Associate
Priest Associate
Priest Associate
Priest Associate
Priest Associate

The Staff

Heidi Cotter, Financial Secretary
Priscilla Hooper, Director of Religious Education
Vaughn Mauren, Organist & Choirmaster

Cheryl C. Batter, Administrator
Randall Martini, Sexton

The Vestry

Ann Cooke, Senior Warden
David Dynowski, Junior Warden
Ollie Bunch, Clerk

Michael Sherrill, Treasurer
Richard M. Wenner, Assistant Treasurer
David Thomas, Facilities Manager

Term Ending 2015

Doug Compton
Ron Coons
Ellen Dollar
Chuck Willson

Term Ending 2016

Michael Fitzsousa
Carol McDermott
Eleanor Michael
Peter Peterson

Term Ending 2017

Kathy Bolt
Ben Parish
Michael Shuey
Judith Stahl

Committees and Organizations

Acolytes:	Ted Newton	Fundraising:	David Dynowski & Sam Paul
Altar Guild:	Cheri Evans, Sue Nelson	Outreach:	Barbara Schiller
Arbor Society/ Planned Giving:	Ted Newton	Parish Life:	
Choir Guild:	Sam Dynowski	Property Committee:	Rachael Desmond David Thomas
Adult Education:	Mark Evans	Readers & Chalice Bearers:	
Education for Ministry:	Ronald Ward	Sound Committee:	Chuck Russo
Endowment & Investments:	Ted Newton	Ushers:	Derrick Kirsch
Finance:	Harry Meyer	The Women of St. James's:	Edwina Bosco

www.stjameswh.org email: info@stjameswh.org 860-521-9620

Address Service Requested

www.stjameswh.org

860-521-9620

West Hartford, CT 06107

19 Walden Street

St. James's Episcopal Church

NON-PROFIT ORG.
U.S. POSTAGE
PAID
Permit No. 3071
Hartford, CT